



Hammond Power
Solutions Inc.

INSTALLATION, OPERATION AND MAINTENANCE GUIDE

FOR INDOOR/OUTDOOR ENCAPSULATED THREE-PHASE TRANSFORMERS

Indoor/Outdoor Encapsulated Three-Phase Transformers

Approved for Installation in
Class 1, Division 2, Groups A, B, C & D
Hazardous Locations



Up To 150 kVA

Hammond Power Solutions Inc.
595 Southgate Drive,
Guelph, Ontario N1G 3W6
Tel: (519) 822-2441
Fax: (519) 822-9701
Web Site: www.hammondpowersolutions.com

Hammond Power Solutions Inc.
1100 Lake Street,
Baraboo, WI 53913-2866
Tel: (608) 356-3921
Fax: (608) 356-2452

Literature No.: **IOMGE3**
Issue Date: April 2006



Safety Precautions

- (1) Do not lift or move a transformer without proper equipment and experienced personnel.
- (2) Do not install the transformer until a full inspection has been completed.
- (3) Use terminals only for electrical connections, and flexible connectors are recommended.
- (4) Connections should only be in accordance with the nameplate diagram or connection drawings.
- (5) Make sure all power is disconnected before attempting any work on a transformer.
- (6) Make certain all ground connections are complete and tightened before energizing the transformer.
- (7) Do not attempt to change any taps - primary or secondary, while the transformer is energized.
- (8) Do not change connections when a transformer is under excitation.
- (9) Do not adjust or remove any accessories or cover plates while the transformer is energized.

Class 1, Division 2, Hazardous Location Installation Requirements

- (1) This equipment is suitable for use in Class 1, Division 2, Groups A, B, C & D hazardous locations or non-hazardous locations only.
- (2) Power, input and output (I/O) wiring must be in accordance with Class 1, Division 2 wiring methods as per Article 501-10 (b) of the National Electrical Code.
- (3) **WARNING - EXPLOSION HAZARD - DO NOT DISCONNECT EQUIPMENT UNLESS POWER HAS BEEN SWITCHED OFF OR THE AREA IS KNOWN TO BE NON-HAZARDOUS.**

AVERTISSEMENT - RISQUE D'EXPLOSION - AVANT DE DECONNECTER L'EQUIPEMENT, COUPER LE COURANT OU S'ASSURER QUE L'EMPLACEMENT EST DESIGNÉ NON DANGEREUX.

CONTENTS

General Information	3
Handling	3
Receiving & Inspection	3
Storage	3
Installation	3
Ventilation	4
Accessibility	4
Sound Levels	4
Cable Connections	4
Grounding	4
Inspection Before Energization	5
Operation	5
Maintenance	5
Diagrams 1 and 2	6



INSTALLATION, OPERATION AND MAINTENANCE OF THREE-PHASE ENCAPSULATED TRANSFORMERS

GENERAL

Three phase encapsulated transformers are manufactured to provide optimum performance for a lifetime of uninterrupted service. Careful attention to the following instructions is recommended for safe and reliable operation.

Installation, operation and maintenance of transformers should be performed by authorized persons, familiar with electrical apparatus and the potential hazards involved.

Warning: Danger! There is the potential of electric shock whenever working in or around electrical equipment such as transformers. Power must be shut off before any work is conducted on a transformer.

As with any electrical device, transformers must be installed according to the requirements of the national, and local electrical codes. Refer to ANSI/IEEE C57-94 may also be referred to for recommended installation, application, operation and maintenance of dry type transformers.

HANDLING

Transformers are either shipped in cartons or palletized. The units on pallets can either be lifted via a forklift truck or hoisted by the lifting lugs provided.

Appropriate lifting equipment should be used relative to the size of each transformer. No attempt should be made to lift or move a transformer from any points on the unit other than those indicated.

Please Note: On units bolted to the pallets, please remove all the shipping bolts located at the mounting holes.

RECEIVING INSPECTION

Immediately after receiving the transformer, it should be inspected for any transit damage and for correctness against the shipping documents.

The unit should be examined for any breaks in its packaging, dented or damaged enclosures or missing parts from the packing list.

If any damage is noted, a claim should be filed immediately with the carrier and a second copy of all pertinent information relative to the order and the circumstances should be filed with the local sales office.

STORAGE

Transformers that will not be immediately installed and energized, should be stored in a clean dry environment away from any environmental airborne contaminants.

It is recommended that transformers be stored in a heated building, in the original packaging.

INSTALLATION

All encapsulated transformers are supplied with a NEMA 3R enclosure. NEMA 3R units may be installed indoors, or outdoors where applicable.

For any outdoor location, the appropriate applicable codes must be followed including cable installation and hardware suitable for outdoor service. Water tight couplings must be used at the knockouts.

Encapsulated transformers must be located in an upright position on walls, posts, beams or other locations capable of supporting their weight.

If encapsulated units are to be either stored or installed outdoors, the unit must either be oriented vertically with the wiring compartment down or you must install an optional gasket kit which will ensure the unit meets a NEMA 4 or 12 rating as to prevent the ingress of moisture.

Mounting Instructions (refer to diagram 1)

1. Select an installation location that is on a non-combustible surface.
2. The mounting location must allow for air circulation around the transformer for cooling purposes. Please refer to the minimum distances stated in the ventilation section.
3. Using the appropriate mounting template provided, drill the top two mounting holes on the mounting surface.
4. Lift the transformer into position and install the top two mounting bolts.
5. With the transformer hanging on the top two mounting bolts, level the unit, then with the wiring compartment cover open, mark and drill the lower mounting hole(s) into the mounting surface.
6. To provide NEMA 3R protection (protection from falling rain), the transformer must be mounted vertically with the mounting tabs facing up. For NEMA 4 or 12 rating install the appropriate optional gasket kit.
7. Install the lower mounting bolt, lock washer, flat washer and rubber washer into the lower mounting hole(s) (see to Diagram 2).



VENTILATION

Encapsulated transformers are required to be installed in an area where they can be cooled by means of the free circulation of air where the average ambient temperature is 30°C (86°F) and should not exceed 40°C (104°F) at any time.

Adequate ventilation is essential for transformers to meet their nameplate kVA capability. Multiple encapsulated transformers should be located at least 2 inches apart on units up to 10kVA and at least 4 inches apart on units over 10kVA, away from any other obstructions to allow free, clean circulation of air.

ACCESSIBILITY

NEC standards require that transformers be accessible for inspection and located accordingly. However, transformers should not be located in areas where stored items are likely to interfere with either natural air convection or the capability to have them inspected. Passage ways or other areas where people could be exposed to live parts during inspection should also be avoided.

Adequate protection should be provided under any circumstances.

TRANSFORMER SOUND LEVELS

Transformers are an electrically energized apparatus and by their nature emit sound due to their component materials.

Transformers are required to meet NEMA standards for the maximum sound levels permissible. These sound level standards vary from 40 to 60 dB and hence, can be an annoyance if located in close proximity to where people work or reside.

Care should therefore be exercised in selecting sites for transformers particularly to avoid sensitive areas like hospitals, classrooms, medical or office facilities.

The following guide lines may be helpful;

- ➔ Units should be mounted away from corners or reflecting walls or ceilings.
- ➔ Cable or other flexible conduit should be considered to make connections.
- ➔ Acoustically absorbing materials could be considered for walls and ceilings around the unit.
- ➔ The location of the unit should be located as far as practical from areas where sound levels could be considered undesirable.

CABLE CONNECTIONS

1. Open the wiring compartment by removing the four cover hex head cap screws and washers.
2. Terminals should be cleaned and electrical joint compounds are recommended for use on all electrical connections.
3. Make the appropriate electrical connection to suit the desired voltages as per the connection diagram on the nameplate. This includes the input connections, output connections and the ground.
4. Make certain to insulate any unused wire leads with marrette connectors and electrical tape.
5. Close the wiring compartment and ensure that the cover screw is tightly secured.

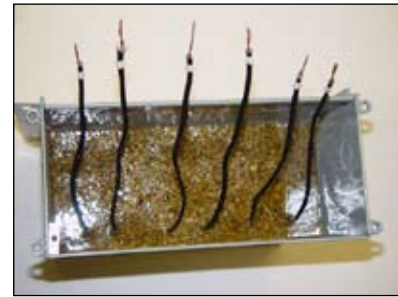

The connecting cable size is determined from the line current rating of the transformers primary and secondary windings. Convenient pre-punched knockouts are provided on all transformer enclosures to facilitate cable entry. (**NOTE:** Once a knockout is removed, encapsulated transformers CANNOT be returned, so ensure the correct unit is to be installed.)

GROUNDING

All core and coil assemblies are solidly grounded to the enclosure internally to ensure that all conductive metal parts have the same potential.

The transformer enclosure in turn should also be securely and effectively grounded as a safety precaution. This grounding should be in accordance with national electrical code standards.

INSPECTION BEFORE ENERGIZATION

For the safe and proper operation of the transformer, we recommend that the following items be checked for completeness:

- a) The insulation resistance, enclosure to primary, enclosure to secondary and primary to secondary, should be greater than 10k ohms.
- b) Before energizing and connecting any loads, please measure and verify the output voltage matches nameplate specifications.
- c) Ensure correct phase connections. Refer to the nameplate vector diagram.



DIAGRAM 1: Typical NQT Series Enclosure Mounting for Three Phase Encapsulated Transformers.

Remove NQT enclosure cover to access the wiring compartment or to install optional NEMA 4/12 gasket.

Lifting Provision on NQT4 and up only.

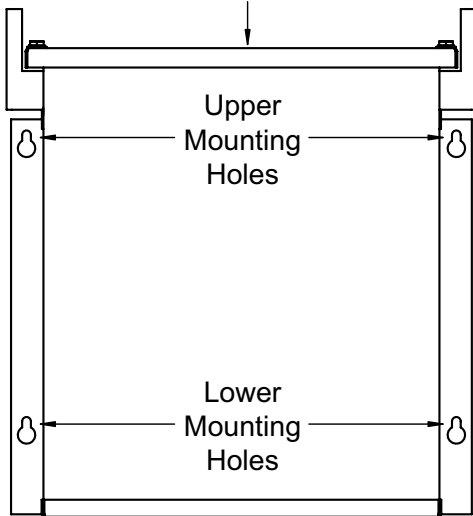

FRONT VIEW

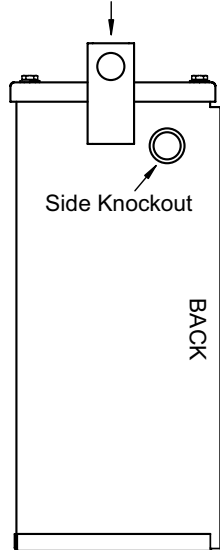

SIDE VIEW

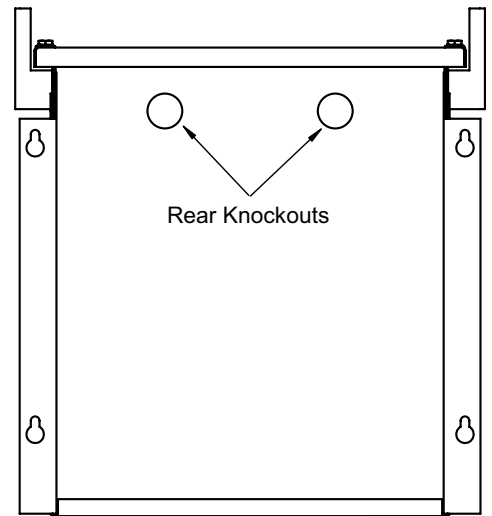

REAR VIEW

DIAGRAM 2: Typical NQT Enclosure Gasket Kit Installation Diagram to convert to a NEMA 4 or 12 Rating.

